

90° Dogleg

For MIL-H-24135/1 Type D, MIL-F-24787/5 Group I, Type D

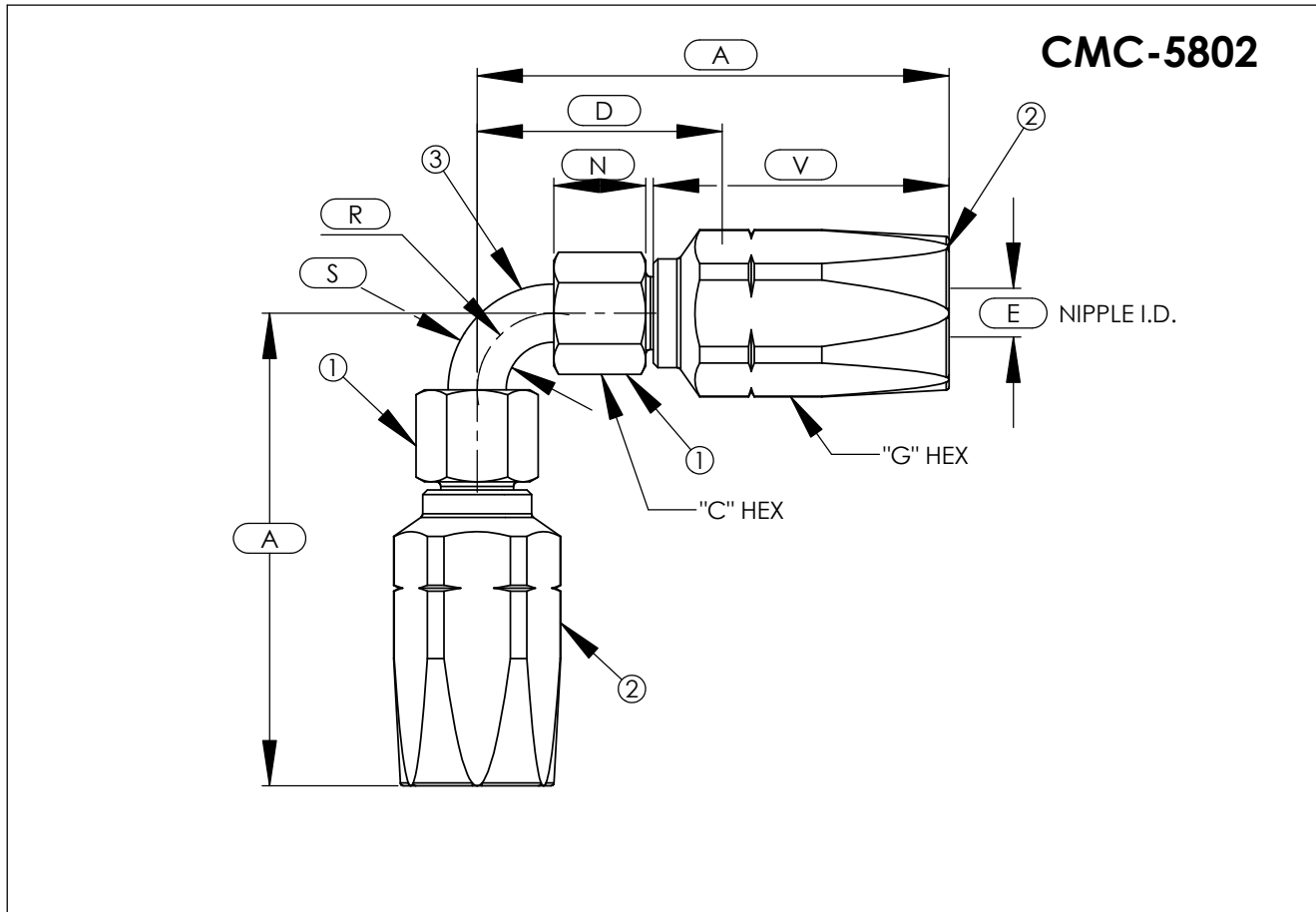

ASSY PART NUMBER	HOSE SIZE	A	C	D	E	G	N	R	S	V
CMC-XX-5802-06-06	3/8	3.11	0.69	1.63	0.31	1.00	0.62	0.50	0.38	1.92
CMC-XX-5802-08-08	1/2	3.44	0.81	1.93	0.39	1.12	0.62	0.75	0.50	2.01
CMC-XX-5802-12-12	3/4	4.52	1.06	2.65	0.61	1.50	0.74	1.25	0.75	2.47
CMC-XX-5802-16-16	1	5.25	1.38	3.20	0.82	1.75	0.74	1.50	1.00	2.95
CMC-XX-5802-20-20	1 1/4	6.09	1.62	3.78	1.05	2.25	0.86	1.75	1.25	3.42
CMC-XX-5802-24-24	1 1/2	6.32	1.88	4.09	1.28	2.50	0.92	2.00	1.50	3.34
CMC-XX-5802-32-32	2	7.38	2.50	4.94	1.75	3.00	1.12	2.50	2.00	3.70

B.O.M.

COMPONENT PART NUMBERS

- ① ALL SIZES-..... NI-5802-(HOSE SIZE)-(MATL CODE)
- ② ALL SIZES-..... SO-5002-(SIZE)-(MATL CODE)
- ③ MONEL- SIZES 6 THRU 12
- ③ COPPER NICKEL- SIZES 6 THRU 32

-EXAMPLE-

CMC-XX-5802-06-06

SEE PAGE 2 FOR ASSY MATERIAL DESIGNATIONS.